

Lightweight solutions for facade maintenance



1. Introduction

Fallprotec has designed several innovative and compact solutions for facade maintenance equipments.

It is thanks to the innovations that integrate the RopeClimber person lifting hoist that a significant reduction in weight of the equipment has been achieved, among which:

- Low weight of synthetic cables of 0.09kg/m for 0,25kg/m for steel cables.
- A battery power supply, which eliminates the electric cable hanging along the facade between the cradle and the suspension rig on the roof.
- Replacement of cable reels through plastic bins for the storage of synthetic cables in the cradle.

The reduction in the weight of the cradle leads to a lighter weight of the suspension rig.

The lifting and transverse movements are powered by battery. Fallprotec offers a wide variety of solutions ranging from the motorized or manual trolleys, the davit and monorail tracks, to a single or two men cradle or a suspended chair.



Fig. 1 RopeClimber hoist

This document highlights the main features of the access equipment provided by Fallprotec. For more detailed information please contact your sale representative.

2. Suspended platform

2.1. Two men cradle

The two-men cradle has a useful surface of 2 x 0.6 m and can accommodate two people or a payload of 240 kg.

The cradle structure is made of aluminum with solid panels on the front and rear. Bumpers protect the facade against shocks.

The cradle is equipped with 2 Ropeclimber hoists with a lifting capacity of 240 kg. The lines are synthetic cables with a diameter of 12 mm, with a breaking strength of 30 kN.

The 4 cables are stored in bins to prevent the cables from hanging under the cradle. This solution is more economical and lighter than that using electric reels to store the cables. Two fall arresters protect the cradle against falls in the event of the hoist malfunctioning.

A centralized electric box receives the control push buttons, in the case of a motorized trolley, an HF control allows remote control of the trolleys. In the electrical box are stored two batteries ensuring the functioning of the cradle during 8 hours of work.

Benefits

- Battery operation
- Light solution
- Cable storage bin



Fig.2 Two men cradle

2.2. One man cradle

The one man cradle has a useful surface of 0.6 x 0.6 m and accommodates a person or a payload of 120 kg.

The basket structure is made of aluminum with solid panels on the front and rear. Bumpers protect the facade against shocks.

The cradle is equipped with one Ropeclimber hoist with a lifting capacity of 240 kg, the lines are synthetic cables with a diameter of 12 mm, with a breaking strength of 30 kN.

The 2 cables are stored in bin to prevent the cables from hanging under the cradle, this solution is more economical and lighter than that using electric reels to store the cables.

A fall arrester protects the cradle against falls in the event of the hoist malfunctioning.

A centralized electric box receives the control push buttons. In the case of a motorized trolley, an HF control allows remote control of the trolley. In the electrical box is stored a battery ensuring the functioning of the cradle during 8 hours of work.

Benefits

- Battery operation
- Light solution
- Cable storage bin



Fig. 3 One man cradle

2.3. RopeClimber Standing chair

The standing chair is a hybrid system allowing the user to work seated as well as standing, so the worker has a wide range of motion and of reach, including over his head. The position of the RopeClimber hoist, below the centre of gravity of the person, increases their “in air” stability. A set of wheels makes it easy to transport. Can be used also with a SafeAccess C rail.

The BackPack version (Fig 5) enables the user to work seated.

- Safety features: fall arrest device on the secondary rope, overload and top limit switch
- Push buttons control box with emergency stop
- Easy use, training as professional climber is not required
- LED that informs about the state of charge of the battery as well as safety features
- Versatile equipment
- Cost-efficient solution
- Battery powered
- Lightweight and compact
- Optimized time of installation
- Ergonomic and comfortable for people working at height
- All accessories are according to EN1808:2015



Fig. 4 Standing chair



Fig. 5 BackPack

3. Suspension rig

The total suspended load of the suspension rig is ranging from 240 kg to 480 kg with an overhang depending of the models ranging from 1,6 to 2,3 m. The suspension rig may be fixed on the roof or mobile mounted on wheels.

3.1. Davit

To clean a facade of small surface the davit is a cost effective solution. To fix the davit on the roof, a series of sockets are installed along or on the parapet.

The davit is made up of a 12 kg jib and a 20 kg mast which can be installed by a single person and dismantled, once maintenance is completed.

Several types of sockets are standardised, two sockets on roof slab of heights 250 and 500 mm and one socket on parapet.

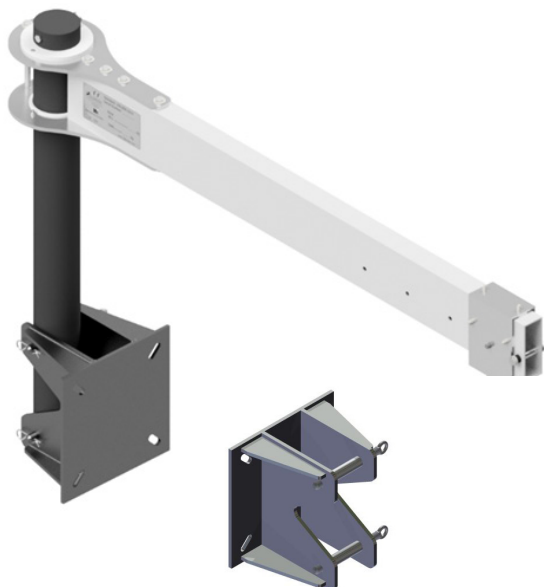

Fig. 6 Fixed davit on parapet



Fig. 7 Fixed davit on roof

Benefits

- Light weight solution thanks to aluminium construction
- May be dismantled once maintenance is completed
- Roof slab or parapet configurations
- Custom made on request
- Cost effective solution

3.2. Mobile suspension rig manually operated

Figure 8 shows a manual trolley traversing on the roof. The stability of the trolley is ensured by two wheel boxes taking up the tilting moment thanks to the aluminum Safeaccess rail fixed on posts to the structure of the roof. The front wheels run on concrete slabs of 50x50x10 cm. In parking position, the mast is tilted horizontally and then removed from the trolley. In service, the jib is pivoted on the roof side to hang the synthetic cables at the 2 anchor points.

Figure 9 shows a manual or motorized trolley traveling on a parapet track system.

Benefits

- Respects the aesthetics of the building
- Can be removed when not in use
- Light solution
- Easy to move
- Horizontal or vertical configuration
- Cost effective solution



Fig. 8 Mobile davit on roof

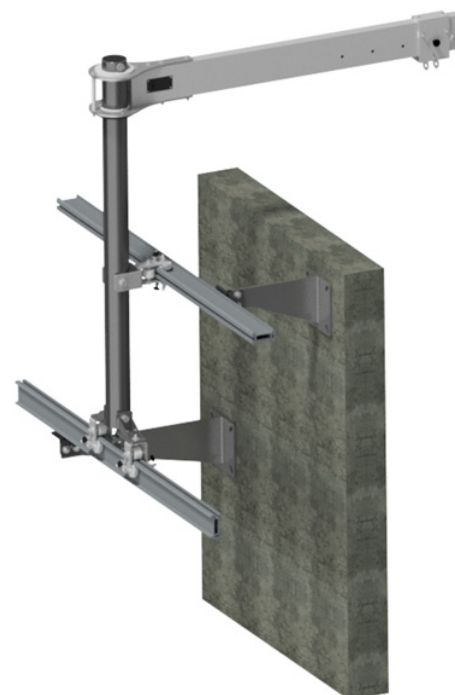

Fig. 9 Mobile davit on parapet

3.3. Powered trolley for one man cradle

The trolley Fig 11 allows to park the cradle on the roof. The trolley is traversing on a track system made of Safeaccess aluminium rails or IPE steel profile.

The trolley is powered by a battery, no need to provide electrical power plugs on the roof, or by main supply.

The trolley is controlled from the cradle by an HF transmission.

In the image Fig 10, the trolley is more compact, the cradle must be parked at the bottom of the building in a parking lot.

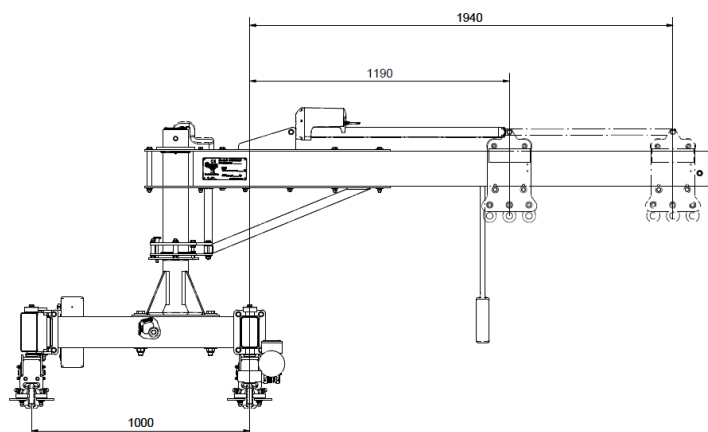
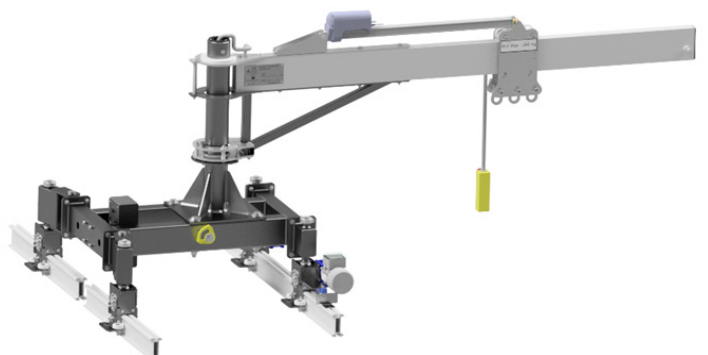

Fig. 10 Compact mobile cradle

Benefits

- Battery or mains operation
- Slewing jib
- Adaptable to different roof constructions
- Respects the aesthetics of the building
- Easy to use

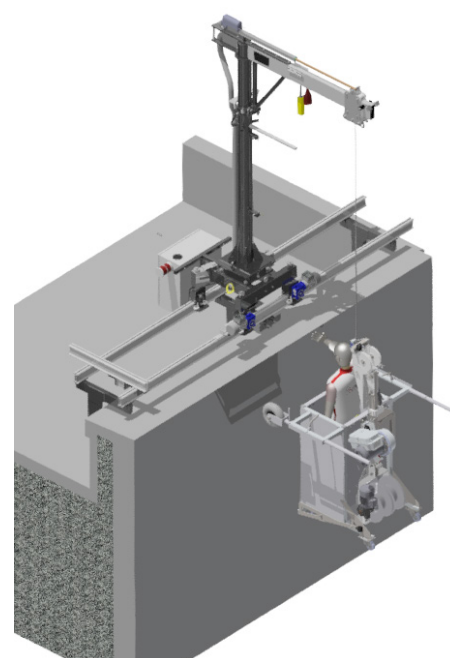

Fig. 11 Mobile cradle

3.4. Powered trolley for 2 men cradle

A more compact trolley may be supplied as per Fig.12 an additional crossbar is fitted at the end of the jib to attach the 4 suspension lines, the cradle must be parked at the bottom of the building in a parking lot. The trolley is traversing on a track system made of SafeAccess aluminium rails or IPE steel profile. The trolley is powered by a battery, no need to provide electrical power plugs on the roof, or by main supply. The trolley is controlled from the cradle by an HF transmission. When the maintenance work is done, the jibs are turned 180° to put the cradle on the roof. The trolley Figure 13 allows to park the cradle on the roof.

Benefits

- Battery or mains operation
- Slewing jib
- Adaptable to different roof constructions
- Respects the aesthetics of the building
- Easy to use

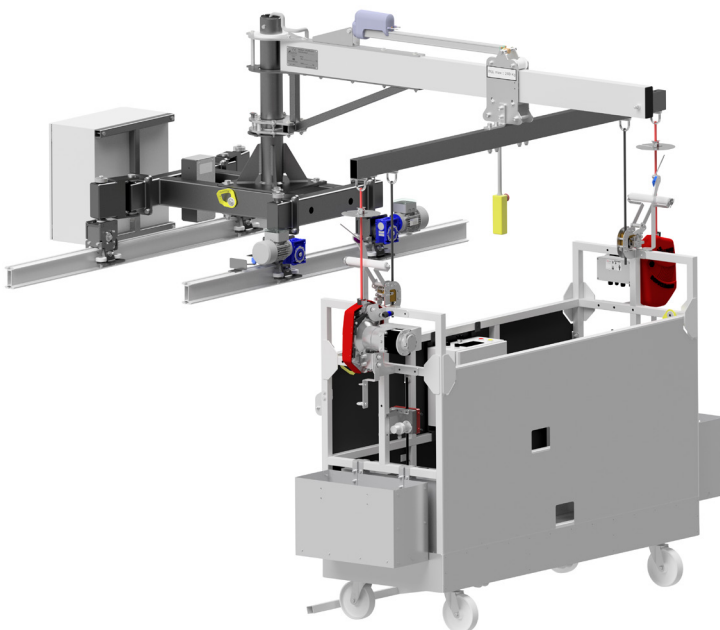

Fig. 12 Trolley for 2 men cradle

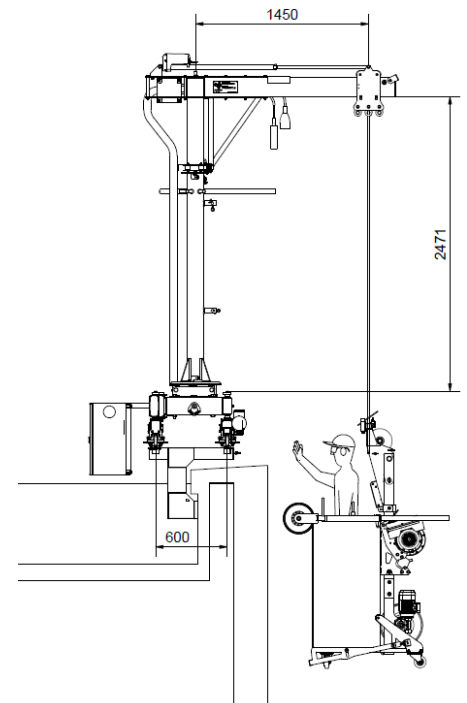

Fig. 13 Trolley for 2 men cradle

3.5. Monorail track SafeAccess

SafeAccess consists of an aluminium rail fixed to the structure of the building by a series of supports and one or two trolleys from which are suspended a cradle or a bosun chair. Installed at the time of construction or on an existing building, it is attached to the facade or to the ceiling for cleaning facades.

NAV trolleys are either manual or motorized on mains or on battery.

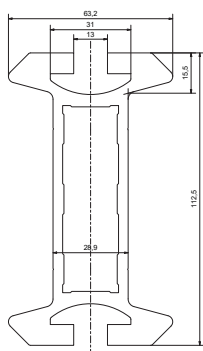

Fig. 13 SafeAccess rail

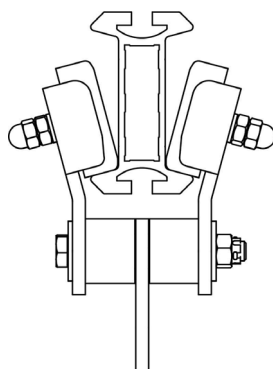
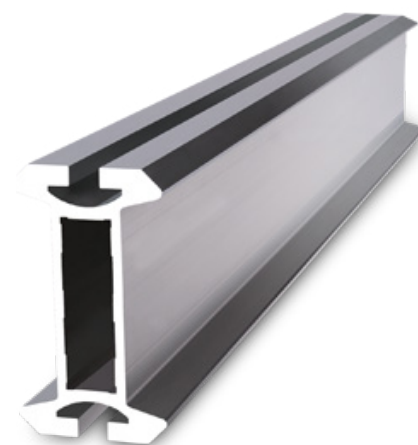
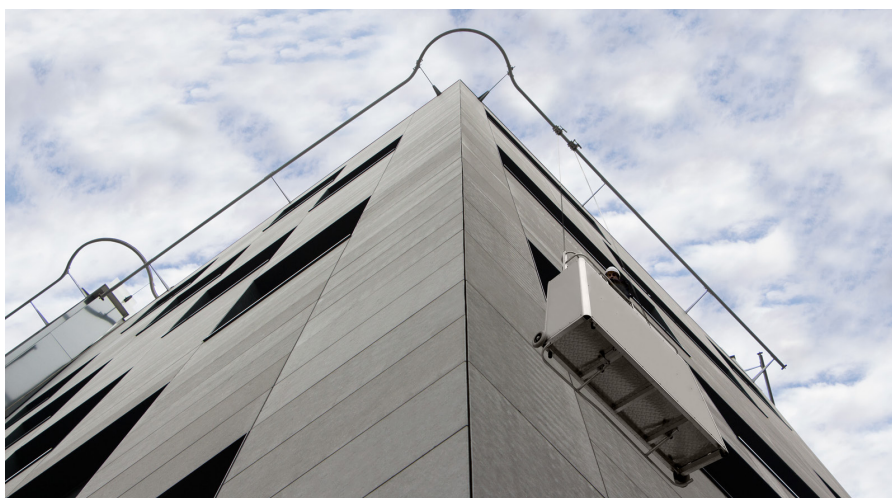

Fig. 14 NAV Trolley

Benefits

- Versatile system
- Possibility to bend the rail
- Cost effective solution
- Option to powder-coat the rail in any RAL color



3.6. Monorail track SafeAccess C

The SafeAccess C is a discreet rail concealed in a false ceiling or under the ceiling. It integrates harmoniously with the aesthetic aspect of the building. The rail can be bent and powder coated in any RAL color. Tailor-made mounting brackets allow its exact alignment with the ceiling. The trolleys run inside the rail. Manual, motorized or battery-powered trolleys allow horizontal traversing. Compatible with rope access technicians, RopeClimber suspended chair and cradle.

PILOT trolleys are either manual or motorized on mains or on battery.

Benefits

- Versatile system
- Can be hidden in the ceiling
- Possibility to bend the rail
- Cost effective solution
- Option to powder-coat the rail in any RAL color

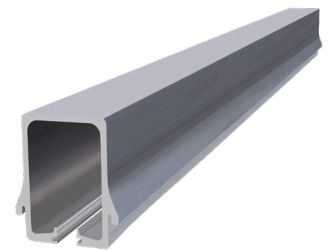

Fig. 15 SafeAccess C rail

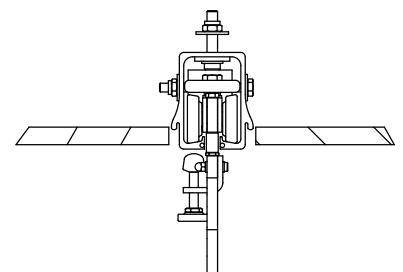

Fig. 16 PILOT trolley